

03-2	REAR THRUST PAD	1	SIC CERAMIC	∅23X4	P2322109	05	OUTER DRIVE RING	1		∅86X86	F2509186	11	SET SCREW	2	S435	M6X10	P9116430
03-1	SPINDLE HOLDER	1	ETFE	∅25X64	A2372356	04-4	IMPELLER COVER	1	ETFE	∅107.5X18	F2452190	10	HEXAGON HEAD BOLT w/t P.W.(∅11.5X∅6.4Xt1.6)	6	SUS304	M6X55	P9119009
03	REAR CASING	1	ETFE	∅123.5X74	A2302131	04-3	INNER MAGNET	1	Sr. FERRITE	∅50X50	F2442185	09	O. RING	2	FKM	∅19.8X∅2.4	P20
02-2	FLANGE	2	ETFE	25A	P2232756	04-2	MOUTH RING	1	RULON	∅34X5	P2422112	08	O. RING	1	FKM	∅109.4X∅3.1	G110
02-1	FRONT THRUST PAD	1	SIC CERAMIC	∅40X7	P2222106	04-1	IMPELLER VANE	1	ETFE	∅107.5X76.5	F2412189	07	BACK UP RING	1	SUS304	∅98X4.5	A2112804
02	FRONT CASING	1	ETFE	∅123.5X87.5	P2202061	04	IMPELLER ASS'Y	1	ETFE		F2402191	06	BEARING	1	SIC CERAMIC CARBON RULON	∅25X35	P2462837 P2462856 A2462917 P2462065
01	MOTOR	1	250W , 2P 3∅ 200/400V,220/380V			03-4	O. RING	1	TEFLON	∅13.8X∅2.4	P14	05-2	OUTER MAGNET	1	Sr. FERRITE	∅80X30	F2522192
						03-3	SPINDLE	1	SIC CERAMIC	∅14X60	P2332110	05-1	MAGNET HOUSING	1	ADC-12	∅86X86	P2512114
NO	PART NAME	Q'TY	MATERIAL	NOTE	DWG. NO.	NO	PART NAME	Q'TY	MATERIAL	NOTE	DWG. NO.	NO	PART NAME	Q'TY	MATERIAL	NOTE	DWG. NO.

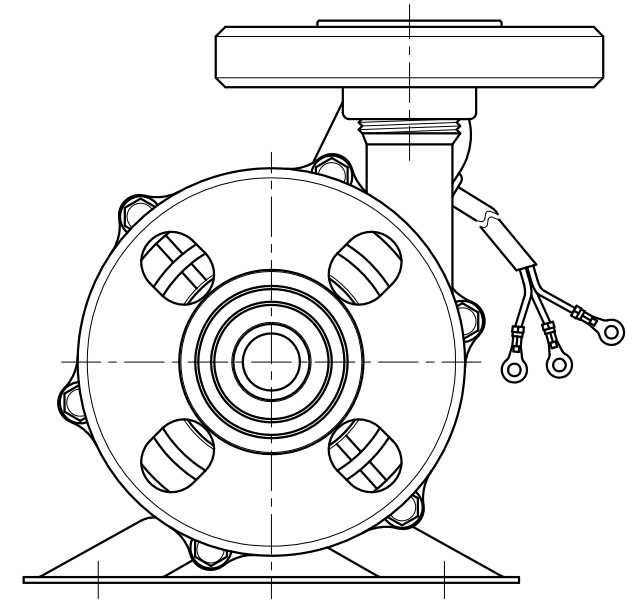
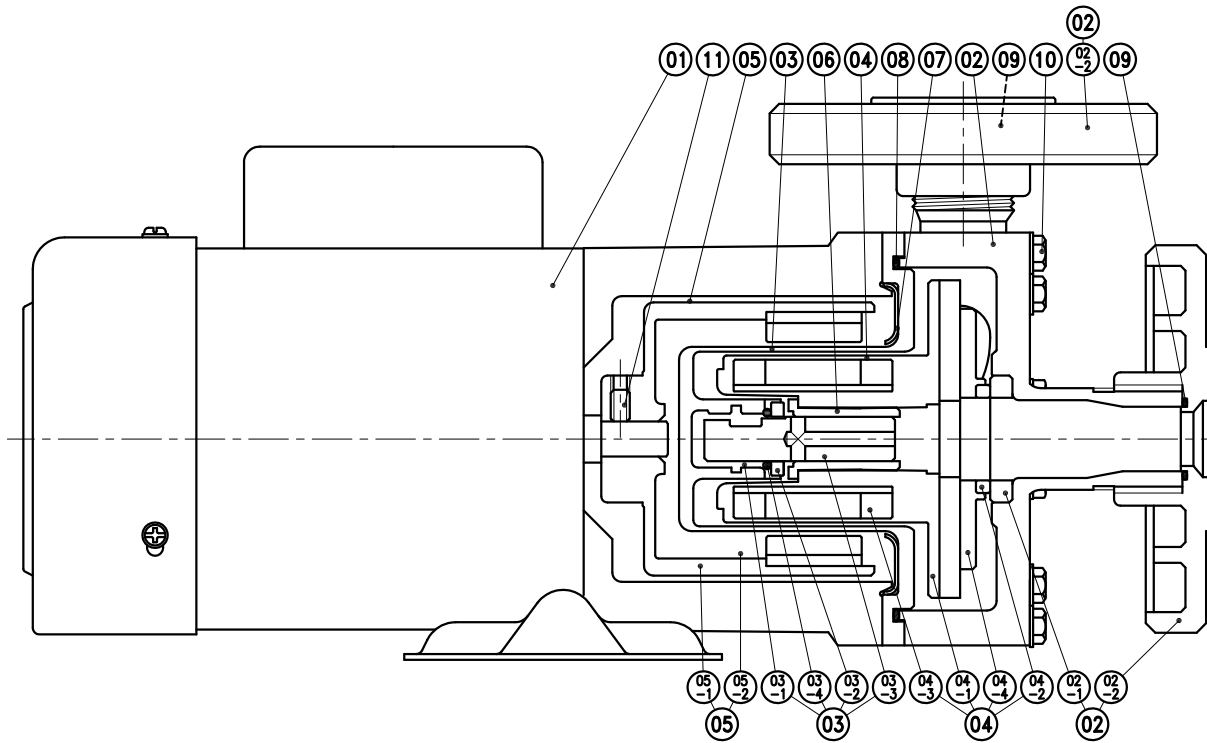

APPROVED		MDL, NAME	NH-275PS-F	
UNIT	MM	CHECK	06 13 14	
SCALE	3:5	DESIGN	06 13 14	
EDITION	1	DR.BY	06 13 14 FANNY	
TPW HONG YUAN		DWG, NAME	CONSTRUCTION DRAWING	
		DWG, NO.	T2272187	A3
		 PAN WORLD CO.,LTD. パンワールド株式会社		