

02-1	FLANGE	2	PvdF	25A	11	SET SCREW	2	S435	M6X10
02	FRONT CASING	1	PvdF	SIC CERAMIC	10	HEAXGON HEAD BOLT w/t PLAIN WASHER	6	SUS304	M6X55
01	MOTOR	1	250W,2P	100~120V 200~240V	09	O. RING	2	FKM	P20
					08	O. RING	1	FKM	G110
NO	PART NAME	Q'TY	MATERIAL	NOTE	07	BACK UP RING	1	SUS304	φ98X4.5
					06	BEARING	1	SIC CERAMIC CARBON RULON	φ25X35
					05	OUTER DRIVE RING	1	ADC-12	φ86X86
					04	IMPELLER ASS'Y	1	ETFE	
					03	REAR CASING	1	PvdF	SIC CERAMIC
NO	PART NAME	Q'TY	MATERIAL	NOTE					

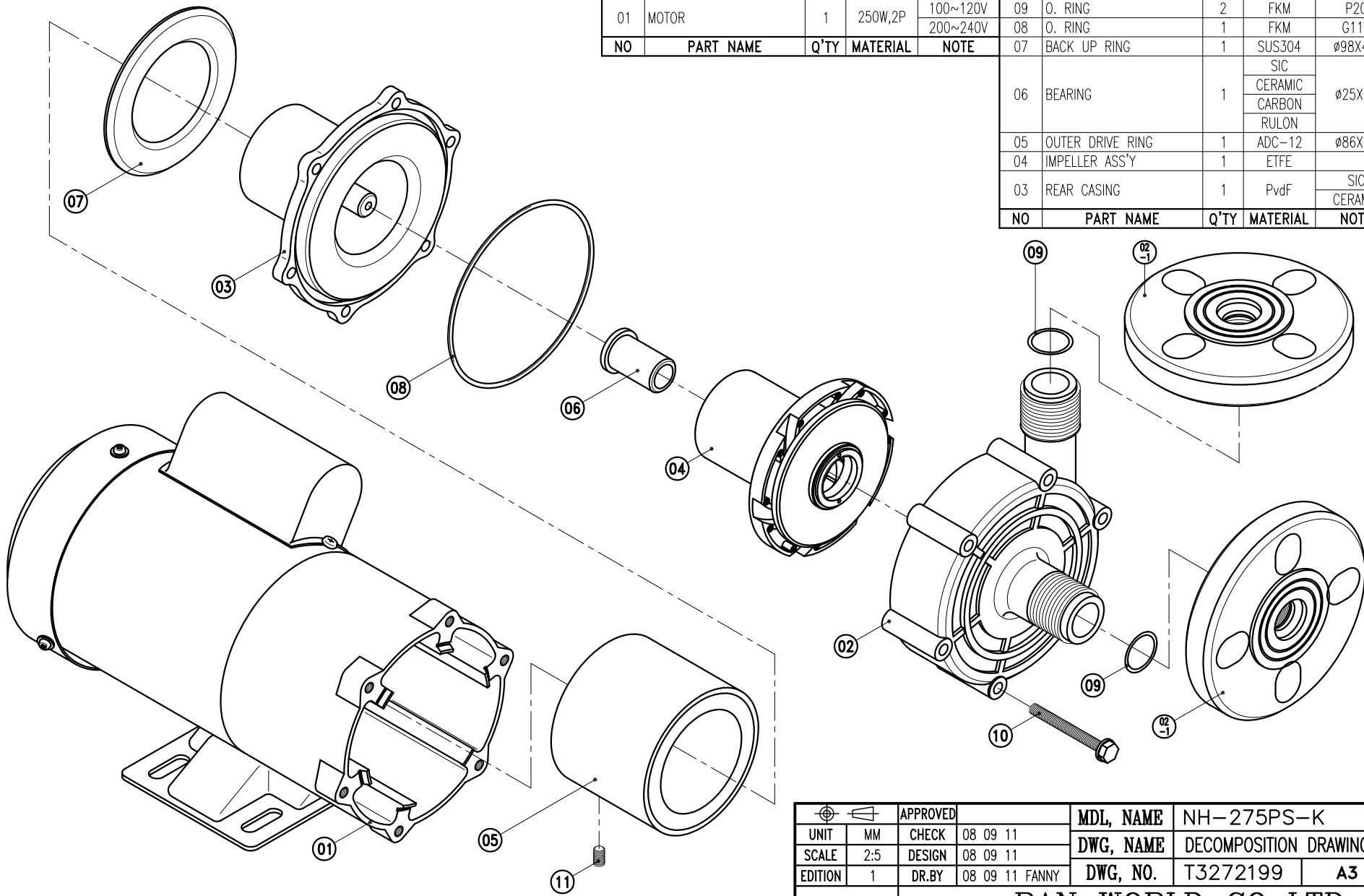

APPROVED		MDL, NAME		NH-275PS-K	
UNIT	MM	CHECK	08 09 11	DWG, NAME	DECOMPOSITION DRAWING
SCALE	2:5	DESIGN	08 09 11	DWG, NO.	T3272199
EDITION	1	DR.BY	08 09 11 FANNY		A3
TPW HONG YUAN		 <b>PAN WORLD CO.,LTD.</b> <b>パンワールド株式会社</b>			