

07	SCREW,CROSS RECESS HEAD w/t PLAIN WASHER	4	SUS304	M3X22	
06	O. RING	1	FKM	S45	1201112301
05	OUTER DRIVE RING	1	ADC-12	φ41X62.5	
04	IMPELLER VANE	1	PPG	φ40X22.5	1001112304
03	REAR CASING	1	PPS	φ54X28.5	1901212305
02-1	FRONT THRUST PAD	1	RULON	φ9X1.2	
02	FRONT CASING	1	PPS	HOSE	1901112310
				THREAD	1901112313
01	MOTOR	1	5W,2P	100~120V	1911212309
				200~240V	1911212308
NO	PART NAME	Q'TY	MATERIAL	NOTE	PART NO.

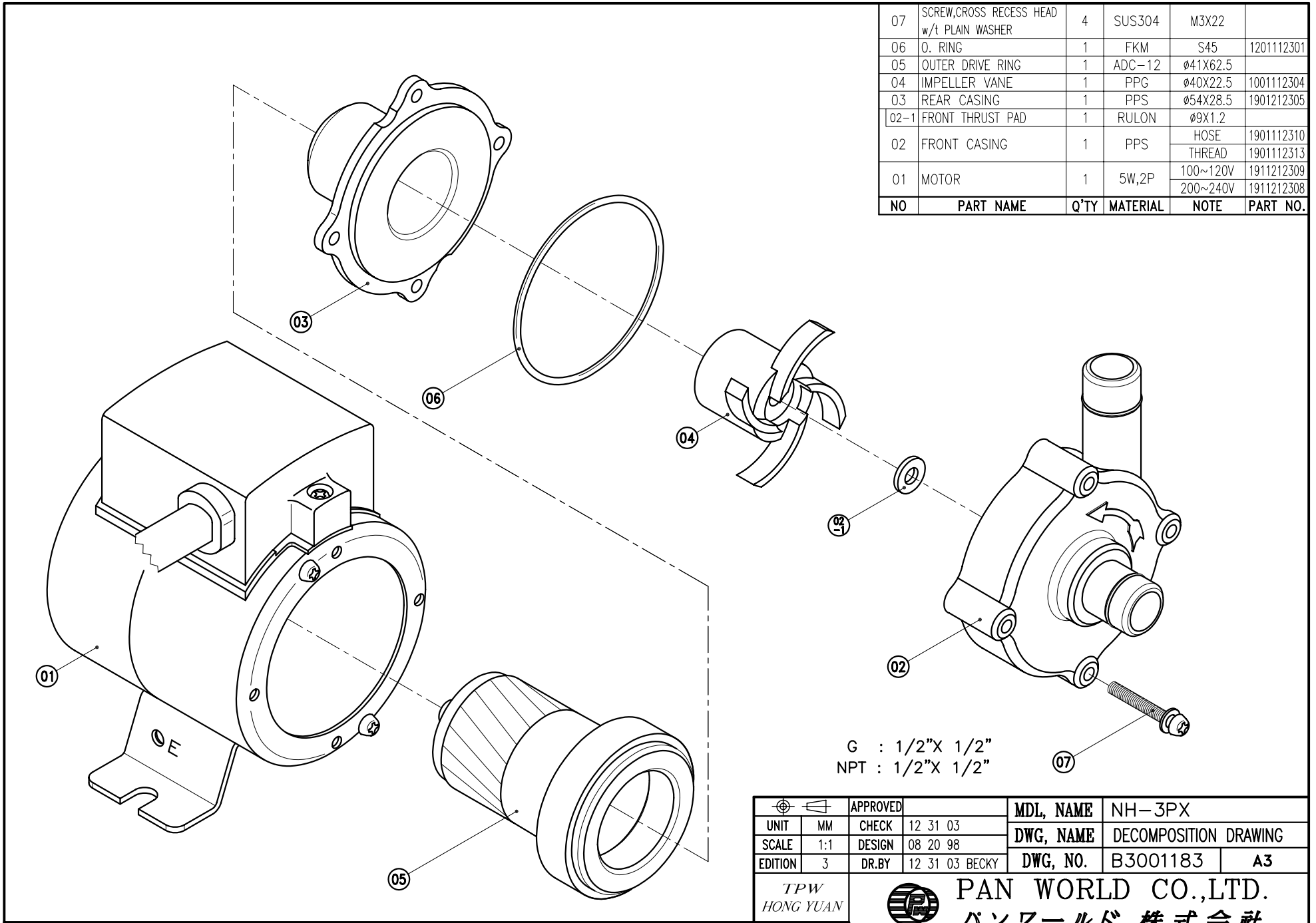

G : 1/2" X 1/2"  
NPT : 1/2" X 1/2"

APPROVED		MDL, NAME	NH-3PX	
UNIT	MM	CHECK	12 31 03	
SCALE	1:1	DESIGN	08 20 98	
EDITION	3	DR.BY	12 31 03 BECKY	DWG, NO. B3001183
TPW HONG YUAN		PAN WORLD CO.,LTD. パンワールド株式会社		