

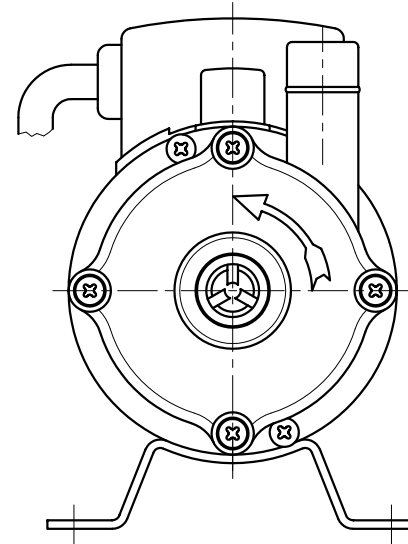

02-2	SPINDLE	1	CERAMIC	∅4X29.7	P2331107	05	OUTER DRIVE RING	1		∅41X62.5	P2501413	07	SCREW,CROSS RECESS HEAD w/t P.W.(∅6X∅3.2Xt0.5)	4	SUS304	M3X22	P9111721
02-1	FRONT THRUST PAD	1	RULON	∅9X∅4.2X1.2	A2221580	04-1	INNER MAGNET	1	FERRITE	∅18X12	P2441115	06	O. RING	1	FKM	∅44.5X∅2	S45
02	FRONT CASING ASS'Y	1	PPS	∅54X35	P2201370	04	IMPELLER VANE	1	PPG	∅40X22.5	P2401035	05-2	OUTER MAGNET	1	FERRITE	∅38X∅25X10	P2521094
01	MOTOR			100~120V,200~240V , 5W,1∅,2P		03	REAR CASING	1	PPS	∅54X28.5	P2301369	05-1	MAGNET HOUSING	1		∅41X59.5	P1201373
NO	PART NAME	Q'TY	MATERIAL	NOTE	DWG. NO.	NO	PART NAME	Q'TY	MATERIAL	NOTE	DWG. NO.	NO	PART NAME	Q'TY	MATERIAL	NOTE	DWG. NO.

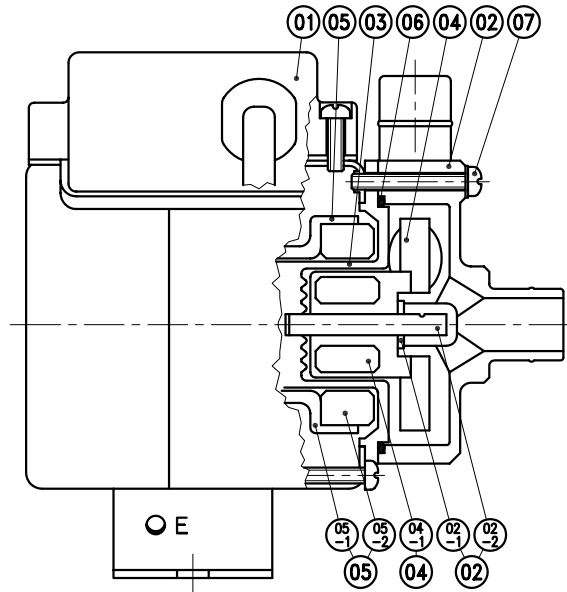

G : 1/2"X 1/2"
NPT : 1/2"X 1/2"

APPROVED		MDL. NAME		NH-3PX	
UNIT	MM	CHECK	12 31 03	DWG. NAME	CONSTRUCTION DRAWING
SCALE	1:1	DESIGN	09 01 98	DWG. NO.	B2001182
EDITION	3	DR. BY	12 31 03 BECKY		A3
TPW HONG YUAN		 PAN WORLD CO.,LTD. パンワールド株式会社			