

# Operation and Maintenance

## PH Series

### C O N T E N T S

	Page
UNPACKING	1
PRECAUTIONS	1
INSTALLATION, PIPING AND WIRING	2
OPERATION	7
TROUBLESHOOTING	9
MAINTENANCE AND INSPECTION	11

## UNPACKING AND CHECKING

Upon receiving the goods, inspect for external damage and check that the goods, including accessories, agree with your order and no bolts have become loose during shipment. Inform your agent of the model and serial number shown on the name plate when reporting any problems.

## PRECAUTIONS

### **1. DRY RUNNING AND CAVITATION**

In normal circumstances, dry running must be avoided, because the pump bearings are lubrication and cooled by the liquid being pumped. In the case of unavoidable dry running, such as in a trial operation to confirm the direction of motor rotation etc., stop the pump within several seconds and wait at least one hour. Then allow liquid into the pump to cool ceramic parts and prevent cracks. Cavitation and running at the closure of the suction and or discharge valve can damage the pump interior or cause abnormal wear due to increasing temperature and friction of contact parts. In such cases, the pump should be stopped within one minute.

### **2. OPERATION TEMPERATURE**

The pump should be operated within the following temperature range:

Atmospheric temperature : 0~40°C

Pumping water temperature : 0~70°C (PH series)

Refer to the Chemical Resistance Chart for the recommended temperature range of each fluid.

Viscosity, vapor pressure and corrosiveness of the pumping fluid may vary with changes in temperature. Thus careful attention should be paid to changes in pumping fluid characteristics.

### 3. PERMISSIBLE SYSTEM PRESSURE OF PUMPS

Discharge pressure should not exceed the following pressures.

<u>Model</u>	<u>Pressure</u>
3012PH	3.9 kg f / cm <sup>2</sup>
3013PH	5.4 kg f / cm <sup>2</sup>
3024PH	7.6 kg f / cm <sup>2</sup>
3026PH	10.5 kg f / cm <sup>2</sup>
4012PH	3.7 kg f / cm <sup>2</sup>
4013PH	5.1 kg f / cm <sup>2</sup>
4024PH	7.3 kg f / cm <sup>2</sup>
4026PH	10.2 kg f / cm <sup>2</sup>

### 4. PERFORMANCE CHANGE DUE TO SPECIFIC GRAVITY AND VISCOSITY

The power requirement discharge and head will be change when the specific gravity and viscosity of the pumping fluid are higher than that of fresh water. Since the pump is recommended according the purchase specification, contact Pan World or agent if the pump is used for another service.

### 5. SLURRY HANDLING

As a rule, the pump is unsuitable for slurry. Only type PH with a ceramic bearing is available for applications of up 5% slurry concentration, particle size of 50 microns meter and hardness of 80 Hs.

### 6. DEGREASING

The ceramic bearing of type PH is greased to make test operation smooth. When the fluid must be protected from contamination with the fluorocarbon grease, wipe it away before pump operation.

## INSTALLATION, PIPING AND WIRING

### 1. PLACE OF INSTALLATION

- i. The pump should be installed as near to a suction tank as possible and readily accessible for inspection and maintenance.
- ii. In order to ensure safety during disasters such as floods, provisions should be established for the motor and the power distribution unit.

## 2. FOUNDATION

- i. Prepare concrete foundations suitable for the weight of the pump and enough depth to resist frost in freezing weather.
- ii. The surface should be level. Make sufficiency large for anchor bolts to suit pump. As much times as possible should be allowed for the concrete to harden 28 days usually being advisable.

## 3. INSTALLATION

- i. The metallic shims on the foundation to leave about 25mm between the surface for the foundation and the base for pouring cement mortar.

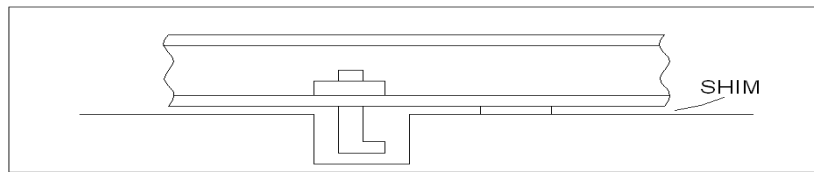

- ii. Mount the pump, with the anchor bolts, on the shims. Fits the nuts to the bolts, flush with their tops, and let the bolts hang down into the holes.
- iii. Be sure that the pump is in a perfectly horizontal.
- iv. Pour cement mortar into the anchor bolts hole and space under the base plate. Allow several days for it to harden. Then tighten the nuts paying particular attention to the level of the pump.

## 4. PIPING **\*\*CAUTION\*\***

All piping should be supported independently so that unnecessary weight and vibration are not transmitted directly to the pump. Flexible piping is recommended to avoid damage of the plastic pump casing. The best piping arrangement for minimum loss is based on straight runs with as few bends and fittings as possible. Do not screw piping excessively on to the pump casing. Screw of the casing is not tapered but straight. Use of O-ring is always recommended for sealing.

### SUCTION PIPING

- i. The suction piping should be as short as possible and with minimum number of small radius bend. Excessive length and sharp change in the direction of flow may lead to flow instability and cavitation.

- ii. The available NPSH should exceed 120% of the required NPSH. See the respective performance curve for the NPSH.
- iii. The suction piping should never be smaller than the pump inlet. The flow velocity must not exceed 2m/sec. When pumping viscous or hot liquids, lower flow velocities may be required to ensure enough NPSH.
- iv. In the case of flooded suction
  - a) The piping should be laid with a slight descent to the pump.
  - b) Install a valve in the suction line for dismantling and checking. The valve should be fully open during operation.
- v. In the case of negative suction
  - a) Upward loops should always be avoided as possible sources of air pockets. Where looping is unavoidable, a downward loop is preferable to an upward loop.

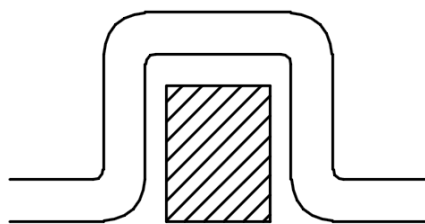

Upward loop is incorrect

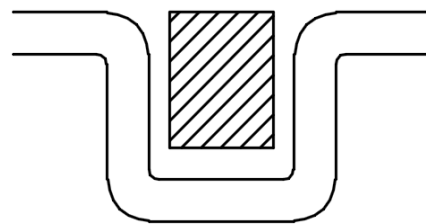

Down loop is correct

Q

Ideally, suction pipe should rise continuously to the pump inlet with a rise of more than 1/100.



Incorrect

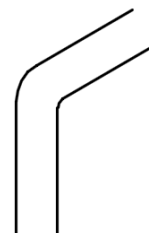

Gradual rise

Correct

- b) If the piping is buried underground, it is recommended to perform a hydraulic pressure test at 16 kg f/cm before filling up.
- c) If the suction piping is larger than the pump inlet, connect them with an eccentric reducer. Do not use a symmetrical reducer as it creates an air pocket in the horizontal line.

- d) If a gate valve is used for any reason, it should be installed with its spindle positioned or perpendicularly downward to prevent an air pocket at the spindle section.
- e) Air leakage from the joints the piping system may cause pump failure.
- f) A screen and a foot valve with a strainer are recommended to prevent foreign matter from entering the pump system.

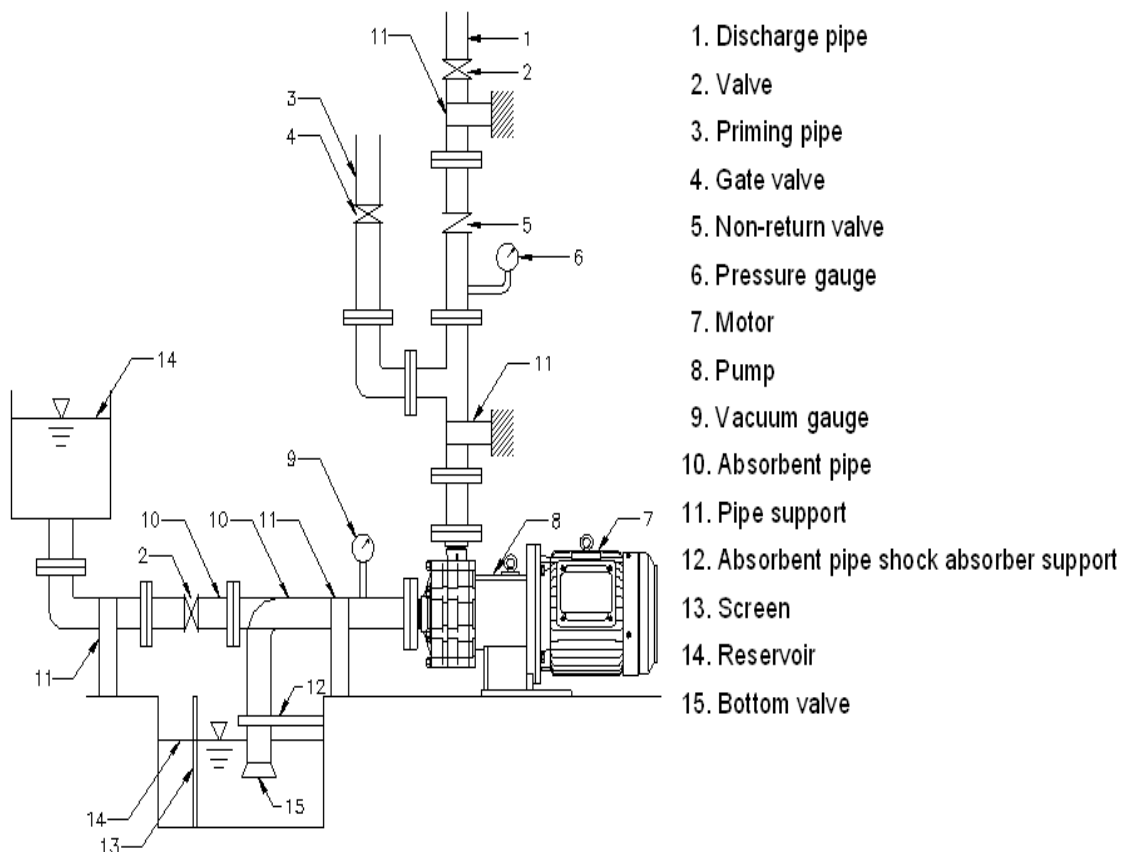

**DISCHARGE PIPING**

- i. Determine the discharge pipe diameter after calculating friction loss head.
- ii. Install a gate valve in the discharge line to control the flow rate and to prevent overload.
- iii. Install a non-return valve in the following conditions:
  - a). If the line is extremely long
  - b). If the static discharge head exceeds 15m
  - c). If the total static head exceeds 9m
  - d). If two or more pumps are connected in parallel to a common piping.

Refer to the above figure for the arrangement order of the gate and non-return valves.

- iv. Install a pressure gauge to monitor the performance of the pump during operation.
- v. If the horizontally laid piping is very long, provide air vents and expansion joints in the discharge line.
- vi. It is advisable to provide drain cocks to wash the piping and to protect the piping from the danger of freezing.

**WIRING**

- i. Provide a push-button switch and an Electro-magnetic relay in accordance with the voltage and out put of the motor.
- ii. Wire in accordance with following circuit diagram. When the pump is installed outdoors, to protect against rain wire with conduits a gasket seal.

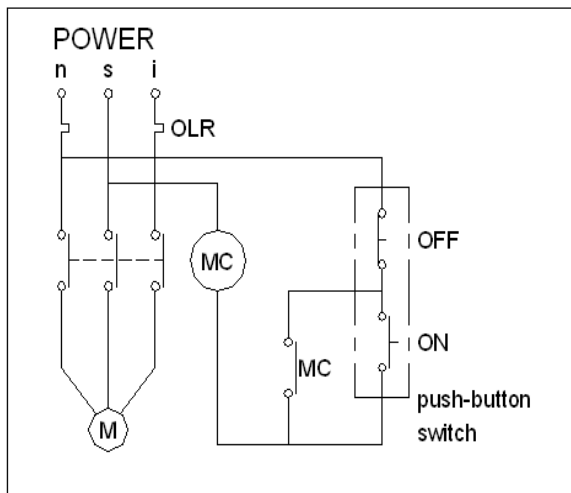

- M..... Motor
- OLR..... Overload relay
- ON , OFF... Push-button switch
- MC..... Electro-magnet relay
- TR..... Time relay
- AR..... Auxiliary relay
- R..... Resistor

## OPERATION

### 1. POINTS OF CARE IN OPERATION

i. **DRY RUNNING**

Dry running must be avoided. Before operating, make sure that the pump is primed.

ii. **CAVITATION**

Cavitation damages the bearing or causes abnormal wear therefore the pump should be stopped within one minute under cavitation running.

Do not close the suction gate valve while the pump is in operation.

iii. **MAGNET COUPLING**

When the magnet coupling is disconnected due to overload or other reason, stop the pump within one minute. If the pump is operated for a longer period under these conditions, the magnet coupling torque is demagnetized.

iv. **VARIATION OF LIQUID TEMPERATURE**

If the temperature of the liquid varies  $80^{\circ}\text{C}$ , the ceramic components may crack.

v. **ELECTRIC FAILURE**

When the electric power gives out press the push-button "OFF" at once and closes the discharge gates valve.

### 2. STARTING PROCEDURE

i. Thoroughly wash foreign matter from all pipes and the reservoir, with clean water. Check that every bolt is fastened securely.

ii. Closed the cocks of the pressure and vacuum gauges. Open the cocks only when measuring and always keep closed after use.

iii. Fully open the suction gate valves and partly opens the valve on the discharge line.

iv. For suction-lift application, priming the pump, turn motor-fan with a screwdriver to rotate the pump impeller to drive away the residual air around the impeller from the air on the discharge pipe. In the case of the flooded suction, check by the suction pressure gauge that liquid is following in the pump.

v. Ensure that the piping and wiring are fitted correctly.



- vi. Turn the motor-fan with a screwdriver and ensure that the fan rotates smoothly.  
Press the push-button “ON” and operate for a few seconds to check that the motor is rotating in the correct direction.  
An arrow shown on the motor indicates the correct rotation. If rotation is incorrect, interchange power source leads of 2 phases.
- vii. Press the push-button “ON” for starting the pump. If the pump fails to start, check the wiring to determine the cause of the trouble.
- viii. Check the discharge pressure and then gradually open the gate valve until the received pressure is reached. When the valve is opened excessively, it will cause overload and magnet coupling disconnection.
- ix. Check that the required flow capacity is obtained. Ensure that the capacity exceeds 10L/min for models NH3012PH, NH3013PH, NH3024PH, NH3026PH, or 20L/min for models NH4012PH, NH4013PH, NH4024PH, NH4026PH and whole PH model.  
Do not close the discharge valve excessively. If a flow meter is not installed, obtain the value of capacity from the values of pressure gauges and amp motor.

### 3. STOPPING

- i. Gradually close the discharge gate valve. Do not close the discharge piping suddenly using a solenoid valve or like. It may damage the pump by water hammer if the piping is long.
- ii. Press the push-button “OFF”. See if the speed of rotation falls slowly and smoothly. If it is not smooth, check the inside of the pump and the drive magnet for any abnormal condition.
- iii. When stopping the pump for an extended period, remove all liquid from the pump or keep the pump warm with a band-heater and open either the discharge or suction gate valve to prevent possible freezing.
- iv. Where a stand-by pump is available, it is recommended that it be used from time to time.
- v. When the electric power gives out, press the push-button “OFF”.

TROUBLESHOOTING

P R O B L E M	C O N D I T I O N		C A U S E	A C T I O N
	WHEN DISCHARGE VALVE IS CLOSED	WHEN DISCHARGE VALVE IS OPENED		
LIQUID IS NOT LIFETD UP		Needles of pressure gauge and vacuum gauge stay at 0	<ul style="list-style-type: none"> <li>• Priming water is not sufficient</li> <li>• Dry running</li> </ul>	<ul style="list-style-type: none"> <li>• Stop the pump and start the pump again with sufficient priming water</li> </ul>
	Priming water goes down too quickly		<ul style="list-style-type: none"> <li>• Foreign matter exists in foot valve</li> </ul>	<ul style="list-style-type: none"> <li>• Clean strainer and foot valve</li> </ul>
	Water drops when discharge valve is opened after starting of pump	Needles of pressure gauge and vacuum gauge swing and drop to 0	<ul style="list-style-type: none"> <li>• Air is penetrating trough suction pipe or gasket</li> <li>• Disconnection of magnet coupling</li> </ul>	<ul style="list-style-type: none"> <li>• Check it flange are sufficiently sealed</li> <li>• Check it suction water level is abnormal low</li> </ul>
	Needle of pressure gauge stays at low position and does not go up		<ul style="list-style-type: none"> <li>• Rotation speed is low</li> <li>• Impeller reverses</li> </ul>	<ul style="list-style-type: none"> <li>• Check power supply and motor</li> <li>• Replace or correct wiring</li> </ul>
		Vacuum gauge shows high value	<ul style="list-style-type: none"> <li>• Strainer is clogged with foreign matter</li> </ul>	<ul style="list-style-type: none"> <li>• Remove foreign matter in strainer</li> </ul>
DISCHARGE CAPACITY IS TOO SMALL	Both pressure gauge and vacuum gauge show normal value	Vacuum gauge indicates very high value	<ul style="list-style-type: none"> <li>• Air pocket exists in suction pipe</li> </ul>	<ul style="list-style-type: none"> <li>• Check arrangement of suction pipe and adjust it property</li> </ul>
			<ul style="list-style-type: none"> <li>• Foreign matter clogs the inlet of impeller</li> </ul>	<ul style="list-style-type: none"> <li>• Disassembly partially then remove foreign matter</li> </ul>
		Needles of vacuum gauge and pressure gauge swing	<ul style="list-style-type: none"> <li>• Air penetrates through suction line</li> </ul>	<ul style="list-style-type: none"> <li>• Check flange are sufficiently sealed</li> </ul>
			<ul style="list-style-type: none"> <li>• Foreign matter clogs the discharge side of pump</li> </ul>	<ul style="list-style-type: none"> <li>• Remove foreign matter</li> </ul>
		Vacuum gauge shows high value, but pressure gauge shows normal value	<ul style="list-style-type: none"> <li>• Air pocket or some resistance exists in suction pipe</li> </ul>	<ul style="list-style-type: none"> <li>• Check it a rising part exists in suction line</li> <li>• Clean suction pipe</li> </ul>
		Pressure gauge shows high value, while vacuum gauge shows normal value	<ul style="list-style-type: none"> <li>• Total dynamic head is higher than planned values</li> </ul>	<ul style="list-style-type: none"> <li>• Check dynamic head including friction loss</li> </ul>
	Both pressure gauge and vacuum gauge show low value	Both pressure gauge and vacuum gauge show low value	<ul style="list-style-type: none"> <li>• Direction of rotation is incorrect</li> </ul>	<ul style="list-style-type: none"> <li>• Change wiring arrangement.</li> </ul>

TROUBLESHOOTING cont'd

PROBLEM	CONDITION		CAUSE	ACTION
	WHEN DISCHARGE VALVE IS CLOSED	WHEN DISCHARGE VALVE IS OPENED		
MOTOR IS OVERHEATED			<ul style="list-style-type: none"> <li>• Voltage drop</li> <li>• Overload</li> <li>• Ambient temperature is too high</li> </ul>	<ul style="list-style-type: none"> <li>• Take necessary measure if voltage or frequency are incorrect</li> <li>• Check if specific gravity and viscosity of the liquid are proper</li> <li>• If motor-fan does not rotate smoothly with a screwdriver, make sure that there is no foreign matter in pump and around pump bearing</li> <li>• Make draught condition better</li> </ul>
DISCHARGE CAPACITY SUDDENLY DROPS		Vacuum gauge shows high value	<ul style="list-style-type: none"> <li>• Strainer is clogged with foreign matter</li> </ul>	<ul style="list-style-type: none"> <li>• Remove foreign matter</li> </ul>
PUMP VIBRATES			<ul style="list-style-type: none"> <li>• Incomplete foundation</li> <li>• Mounting bolts are loose</li> <li>• Cavitation exists</li> <li>• Pump bearing, spindle or magnet capsule broke, worn or melt down</li> <li>• Drive magnet broke</li> <li>• Motor bearing worn</li> </ul>	<ul style="list-style-type: none"> <li>• Make proper foundation</li> <li>• Retighten them</li> <li>• Check suction piping and NPSH</li> <li>• Replace with new one</li> <li>• Replace with new one</li> <li>• Replace with new one</li> </ul>

## MAINTENANCE AND INSPECTION

An overhaul every 3 months mentioned below is recommended. Daily inspection of discharge and suction pressure, flow rate, vibration, voltage, noise and the electric motor current is recommended to detect pump failure earlier. When any abnormal condition is found, contact Pan World or agent.

If a stand-by pump is installed, be sure to operate it once in a while so that it can be operated at any time.

PART	CHECK POINT OR CARE
Drive magnet assembly	<ul style="list-style-type: none"> <li>* Check that there is no rubbing contact</li> <li>* Check to see if drive magnet assembly is correctly mounted and positioned on motor shaft</li> </ul>
Rear casing	<ul style="list-style-type: none"> <li>* Check that there is no crack or trace of rubbing on outside of rear casing</li> <li>* Check that there is no trace of abnormal wear and no crack on rear thrust ring</li> <li>* Wash and clean</li> </ul>
Magnet capsule	<ul style="list-style-type: none"> <li>* Check that there is no crack or trace of rubbing</li> <li>* Wash and clean</li> <li>* Measure inside diameter of bearing</li> </ul>
Impeller, mouth ring	<ul style="list-style-type: none"> <li>* Check that there is no crack or deformation</li> <li>* Wash and clean</li> <li>* Measure thickness of mouth ring</li> </ul>
Front casing	<ul style="list-style-type: none"> <li>* Check that there is no crack</li> <li>* Check that there is no trace of abnormal wear and no crack on front thrust ring</li> <li>* Wash and clean</li> </ul>
Spindle	<ul style="list-style-type: none"> <li>* Check that there is no crack and no trace of abnormal wear</li> <li>* Wash and clean</li> <li>* Measure diameter</li> </ul>
O-ring	<ul style="list-style-type: none"> <li>* Check that there is no crack or no swelling</li> <li>* Replace with new ones every overhaul</li> </ul>