

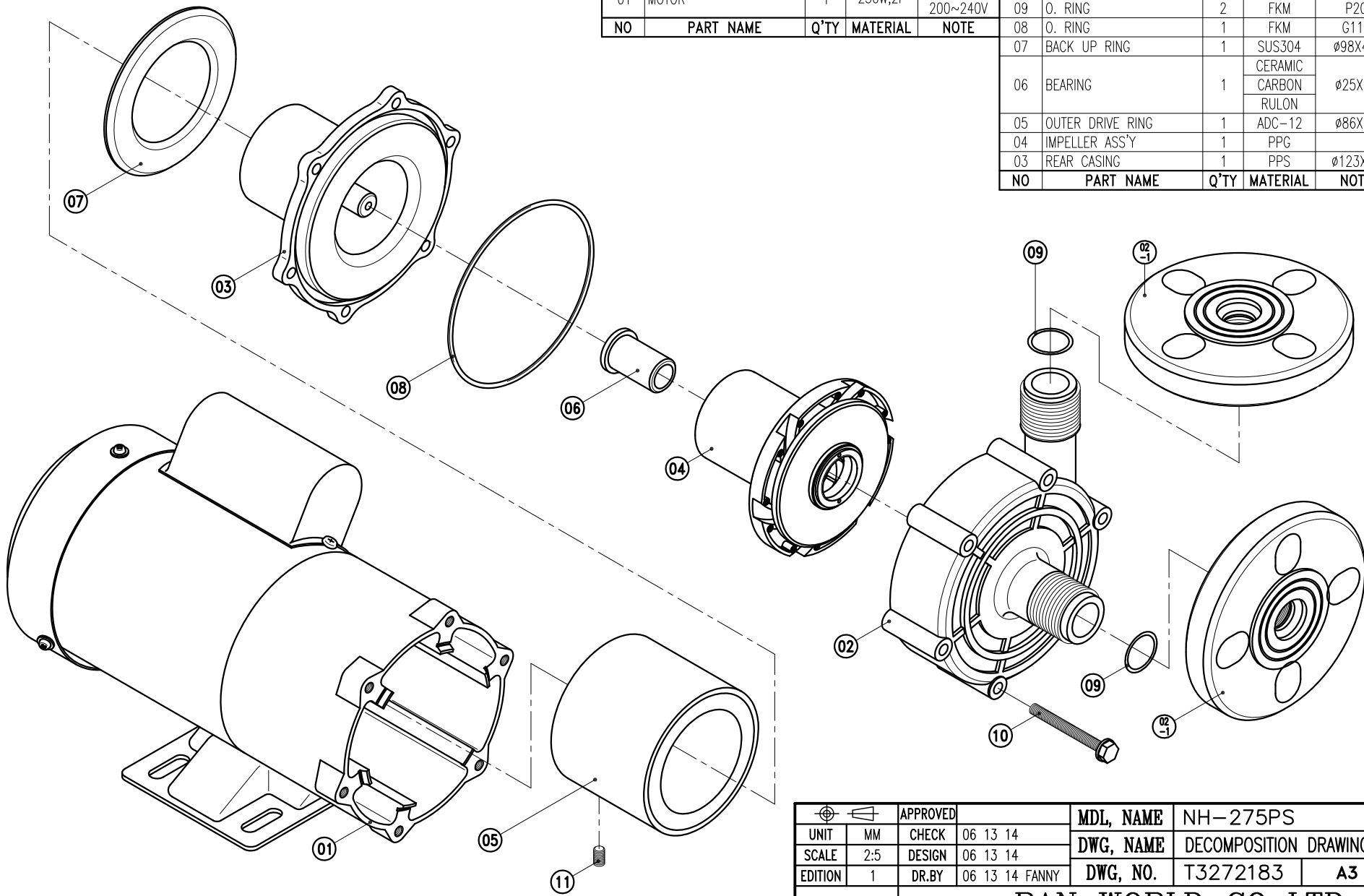

02-1	FLANGE	2	PPG	25A	11	SET SCREW	2	S435	M6X10
02	FRONT CASING	1	PPG	∅123.5X87.5	10	HEAXGON HEAD BOLT w/t PLAIN WASHER	6	SUS304	M6X55
01	MOTOR	1	250W,2P	100~120V 200~240V	09	O. RING	2	FKM	P20
					08	O. RING	1	FKM	G110
					07	BACK UP RING	1	SUS304	∅98X4.5
					06	BEARING	1	CERAMIC CARBON RULON	∅25X35
					05	OUTER DRIVE RING	1	ADC-12	∅86X86
					04	IMPELLER ASS'Y	1	PPG	
					03	REAR CASING	1	PPS	∅123X75
NO	PART NAME	Q'TY	MATERIAL	NOTE	NO	PART NAME	Q'TY	MATERIAL	NOTE



APPROVED				MDL, NAME	NH-275PS	
UNIT	MM	CHECK	06 13 14	DWG, NAME	DECOMPOSITION DRAWING	
SCALE	2:5	DESIGN	06 13 14	DWG, NO.	T3272183	A3
EDITION	1	DR.BY	06 13 14 FANNY			
TPW HONG YUAN				 <b>PAN WORLD CO.,LTD.</b> <b>パンワールド株式会社</b>		